

BELMAR OWNER, LLC

PURCHASE ORDER

11410 Common Oaks Drive
 Raleigh NC 27614
 1-919-455-2900 - 919-455-2909 Fax

P.O. NUMBER	BELM-004
P.O. DATE	9/11/2025
SHIPPING DATE	1/12/2026
SHIP VIA	

TO: Read Window Products LLC
 5900 Weisbrook Lane
 Knoxville TN 37909

SHIP TO: HYATT HOUSE LAKEWOOD (BELMAR)
 7310 WEST ALASKA DRIVE
 LAKEWOOD CO 80226

Contact:
Phone #: (865)288-6226
Fax #:

Contact:
Phone #:
Fax #:

QTY	UOM	DESCRIPTION	UNIT PRICE	AMOUNT	ACCOUNT CODE
212.00	EA	TAG: HHG-90-1 DUAL ROLLER SHADE (WINDOW SIZES DETAILED ON PROPOSAL) FABRIC INCL	347.56	73,682.72	4-01-001
20.00	EA	TAG: HHG-90-2 DUAL ROLLER SHADE ADA ACCESSIBLE (WINDOW SIZES DETAILED ON PROPOSAL) FABRIC INCL MOTORIZED	917.60	18,352.00	4-01-001
21.00	EA	TAG: HHP-90-2 VARIOUS AREAS AND SIZES (SEE ATTACHED PROPOSAL) QTY: 6 LOBBY BILLARD QTY: 11 LOBBY THE COMMONS QTY: 4 LOBBY DINING	176.19	3,699.99	4-01-001
8.00	EA	TAG: HHP-90-3 FITNESS	170.00	1,360.00	4-06-001
14.00	EA	TAG: HHP-90-4 GATHERING ROOM	278.00	3,892.00	4-10-001
5.00	EA	TAG: HHP-91-1 CORRIDORS	184.00	920.00	4-03-001
1.00	EA	4 TRIPS (1 MEASURE AND 3 INSTALL)	7,500.00	7,500.00	4-01-001
3.00	EA	MEASURE FEE	750.00	2,250.00	4-01-001
1.00	EA	INSTALL FEE	28,500.00	28,500.00	4-01-001
Concord Hospitality Enterprises Company is agent for owner, BELMAR OWNER, LLC regarding this purchase order.			TOTAL	\$140,156.71	

TERMS AND CONDITIONS
<p>No shipments will be accepted without 24 hour advance notice of delivery.</p> <p>The P.O. Number must appear on all invoices, bills of lading, and acknowledgements relating to this purchase order.</p> <p>No C.O.D. deliveries accepted.</p>

SEND CORRESPONDENCE TO:
<p>Concord Hospitality Enterprises 11410 Common Oaks Drive Raleigh NC 27614 1-919-455-2900 - 919-455-2909 Fax</p>

9/11/2025

Sarah Forgacs

 APPROVED BY

DATE

Digitally signed by
 Jeff Grace
 Date: 2025.09.11
 14:26:46-04'00'



Carl S Hren Executive VP of Development
 for Concord Hospitality Enterprise
 Company as agent for owner

09/11/25



Terms and Conditions

1. ACCEPTANCE OF CONTRACT: Wherever reference is made to a "Purchase Order" or "PO", such reference shall include these Terms and Conditions, which shall apply to all orders of Goods as defined herein. Any acceptance of this Purchase Order ("PO") is limited to acceptance by Seller of the terms and conditions stated herein, without modification. Any additional or different terms, conditions or instructions proposed by Seller are hereby rejected by Buyer and, unless such variances are in the terms of the description, quantity, price or delivery schedule for the materials, equipment or other items which are the subject of the PO (collectively, the "Goods"), such offer of Seller shall be deemed an acceptance of this PO without such additional or different terms. Seller accepts this PO, including all of these Terms and Conditions, when it: executes and delivers the original copy of this PO to Buyer; when it commences any work on the Goods; or when it delivers or ships any of the Goods to Buyer. However, this Purchase Order is contingent upon the Owner obtaining financing to cover the cost of the Project.
2. EXTENT OF AGREEMENT: To the extent services incidental to the Goods are performed by Seller under this PO, such incidental services shall also be regarded as goods. Nothing set forth in this PO shall be construed to create a contractual relationship between persons or entities other than Buyer and Seller. This Purchase Order is solely for the benefit of Buyer and Seller, represents the entire and integrated agreement between the parties, and supersedes all prior negotiations, representations, or agreements, either written or oral.
3. CHANGES: Purchasing Agent is authorized, on behalf of Buyer, to arrange for the purchase, scheduling and delivery of Goods solely for the project known as [HYATT HOUSE DENVER/LAKEWOOD BELMAR 7310 West Alaska Drive Lakewood, CO 80226] and only for the term of the Procurement Agreement between Buyer and Purchasing Agent. Buyer and Purchasing Agent shall have the right, at any time, to make changes to specifications, drawings, or other data incorporated into this PO or the methods of shipment or packing, place of delivery, and time of delivery (collectively, the "Requirements") of the Goods. Seller shall deliver a list of all deviations or changes from the Requirements to Buyer and Purchasing Agent, in writing, with the corresponding submittal furnished by Seller to Buyer and Purchasing Agent for review. Any difference in price resulting from such changes approved by Buyer following receipt of the list of deviations or changes shall be equitably adjusted and this PO shall be modified in writing accordingly. It is Seller's responsibility to identify any change in cost prior to proceeding with the change. If Seller proceeds without identifying changes in cost, Seller waives all rights to seek additional compensation and all costs associated with said changes shall be Seller's sole responsibility.
4. DRAWINGS AND SPECIFICATIONS: All Requirements submitted to Seller or referred to on the face of this PO are incorporated herein and made a part of this PO. In addition, other general terms and conditions of this PO, including requirements for the submittals and payments for the Goods, and any safety requirements applicable to Buyer, also are attached and incorporated by reference. All Goods furnished shall strictly conform to the Requirements incorporated herein.
5. SUBMITTALS: Seller shall promptly submit for review to Buyer all shop drawings, samples, product data, manufacturers' literature and similar submittals required by this PO. Seller shall be responsible to Buyer for the accuracy and conformity of its submittals. Seller shall prepare and deliver its submittals to Buyer within 7 working days of execution of this PO and in such time and sequence so as to not delay Buyer or others in the performance of the Project. The approval of any Seller submittal shall not be deemed to authorize deviations, substitutions or changes of the Requirements unless express, written approval is first obtained from Buyer expressly authorizing such deviation, substitution or change. In the event Seller is not required to furnish any submittals under this PO, Seller agrees to, upon request of Buyer, submit in a timely fashion to Buyer, for Buyer's review, any shop drawings, samples, product data, manufacturers' literature or similar submittals as may reasonably be required by the Contractor, Owner or Architect/Engineer. Buyer and Owner are entitled to rely on the adequacy, accuracy and completeness of any professional certifications required by the PO concerning the performance criteria of systems, equipment or materials including all relevant calculations and any governing performance requirements.
6. SCHEDULE: **TIME OF SELLER'S PERFORMANCE IS THE ESSENCE OF THE PO.** Seller shall provide Buyer with a full schedule for Buyer's review identifying the period for submission of shop drawings and other submittals, production timing,



material acquisition, shipping, delivery, installation, and all other critical durations. Seller shall also timely provide any schedule updates to ensure schedule compliance.

7. SHIPPING: Shipping instructions furnished by Buyer shall be strictly complied with and shall be considered a part of this PO. Seller shall give Buyer forty-eight (48) hours' notice prior to the delivery of any Goods. Any provisions for delivery of Goods by installment shall not be construed as making the obligations of Seller severable. Shipments sent C.O.D. without Buyer's prior, written consent may be rejected and shall be at Seller's sole risk. Risk of loss and/or damage shall be upon Seller until the Goods are physically delivered to Buyer at the Project or other authorized destination unless otherwise agreed to in writing and signed by Buyer, or unless such loss is recovered through project all risk or equivalent insurance.

8. IMPORTING: Buyer shall at no point be listed as the importer of record of any Goods. Seller (or Seller's Vendor as appropriate) shall be the importer of record and all costs or liabilities related thereto shall be borne exclusively by Seller. Seller shall identify and pay any tariffs, duties or similar such assessments incurred with respect to imported Goods due or otherwise assessed prior to final acceptance of the Goods by Buyer. Buyer's obligations hereunder include without limitation payment of all fines, penalties, or other such amounts due, allegedly due or otherwise relating to tariffs.

9. MATERIALS SAFETY DATA SHEETS(MSDS): Seller shall submit to Buyer all Material Safety Data Sheets required by law for any Goods or other items sold or furnished to Buyer before shipment by Seller.

10. INSPECTION: Except as otherwise provided in this PO, all shipments shall be subject to final inspection by Buyer after receipt by Buyer at final destination. Shipments shall be accompanied by detailed delivery tickets to assist Buyer in its inspection. All delivery tickets must be signed by the designated on-site representative for Buyer. Buyer shall have the right to reject and refuse acceptance of Goods that are not in accordance with the Requirements, and shall have no obligation to pay for Goods so rejected. No substitution or modification of any Goods, component parts, tooling, sources of raw materials, processes, or manufacturing sites may be made without Buyer's prior written consent. Buyer may deduct from any amount owed to Seller under this PO, the reasonable cost of inspecting, transporting and care and custody of Goods or other items that are rejected. Goods not accepted shall, at Buyer's option, be (a) returned to Seller at Seller's expense; (b) held by Buyer at Seller's expense; (c) held by Buyer for an equitable reduction in price; or (d) repaired by Buyer at Seller's expense. Payment for any Goods shall not constitute acceptance. Buyer shall have the right to inspect all Goods during any stage of manufacture or production by Seller or Seller's supplier(s) to audit quality assurance programs, and to otherwise assure quality control in the production and manufacture of the Goods hereunder by Seller or Seller's supplier(s), and Seller shall provide reasonable access, facilities, and assistance for the safe and convenient inspection and/or audit at Seller's plant or its supplier(s) plant. Incorporation of the Goods into the Project shall constitute acceptance by Buyer of such Goods and any incidental services, subject to Seller's warranty obligations. Any inspection, acceptance or payment of Product will not affect Buyer's right to revoke acceptance or pursue other remedies if defects or non-conformities are discovered at a later date, notwithstanding that any defect or non-conformity could have been discovered upon inspection.

11. CANCELLATION OR TERMINATION FOR DEFAULT: Should Seller fail to deliver the Goods or perform the incidental services required within the time provided under this PO, or any mutually agreed upon extension of time, or should Seller fail to perform any of the provisions of this PO or fail to make progress so as to endanger performance of this PO in accordance with its terms, Buyer may cancel this PO and obtain the undelivered Goods by whatever method Buyer may deem expedient. If the unpaid balance of the price for the Goods under the PO exceeds Buyer's expense in securing the remainder of the Goods and other damages incurred by Buyer, such excess shall be paid to Seller. If such damages or expenses exceed such unpaid balance, Seller shall promptly pay the different to Buyer. Such cancellation shall be in writing. The rights and remedies of Buyer provided in this section shall not be exclusive and are in addition to any other rights and remedies provided by law or elsewhere under the PO and applicable Contract Documents.

12. TERMINATION FOR CONVENIENCE: Without prejudice to any other rights or remedies that Buyer may have, Buyer reserves the right to cancel this PO, without liability, by delivering written notice to Seller on or before the shipping date stated in the PO. In addition, Buyer may, at any time, with five (5) days written notice to Seller, terminate this PO for the convenience of Buyer. In the event of such termination for convenience, Buyer shall pay Seller, as its entire and sole compensation, the price of the Goods delivered prior to the date of termination, as stated in the PO, and Buyer shall have no



further liability to Seller hereunder, nor shall Buyer be liable under any circumstances for consequential or incidental damages. Seller shall make its records available at reasonable times and places for Buyer's audit. In the event any cancellation or default of Seller under the PO is later determined to have been improper, such actions shall automatically be deemed a termination for convenience and Seller shall be limited in its recovery strictly to the compensation provided in Article 11 above.

13. REPRESENTATIONS AND WARRANTIES: By acceptance of this PO, Seller represents and warrants that: the Goods, including the packaging, advertising, labels and other materials contained on, with, or relating to the Goods, do not infringe any patent, copyright, trademark, trade name or other proprietary interest of Buyer or any third party and comply with the Federal Trade Commission Act and all other applicable laws, rules and regulations; the Goods and the manufacture, sale, storage, shipping, transportation and billing for the Goods, comply with all provisions of applicable law and with all applicable promulgations of governmental authority, both domestic and foreign; Seller is the lawful owner of the Goods, has good right to sell same and convey good and merchantable title, and the Goods are and will be conveyed free of any and all claims, liens, security interests or other encumbrances. In addition to any warranty in fact or implied by law, Seller hereby expressly warrants that all Goods and other items covered by this PO shall conform to the Requirements or other information furnished or incorporated as part of this PO in accordance with Article 4, and shall be fit and sufficient for the purpose intended, merchantable of good material and workmanship and free from defects. Seller specifically warrants and guarantees the Goods and other items and shall make good at Seller's expense, any defect in materials or workmanship that may be discovered, excluding ordinary wear and tear, abuse, lack of proper maintenance and modification not performed by Seller. These warranties shall survive inspection, acceptance, and payment of and for all Goods and other items. These warranties shall extend to Buyer, its successors, assigns, customers and users of its customers' products and Seller shall provide directly to the ultimate users written evidence of these warranties as required.

14. PRICES AND TERMS OF PAYMENT: The prices and terms stated on this PO and stated herein apply to all shipments made or services rendered hereunder. Buyer shall have no obligation to honor invoices for Goods or services at any increased price unless such increase shall have been confirmed in writing by Buyer to Seller. No charge of any kind not stated on this PO will be allowed unless specifically agreed to in advance by Buyer in writing. Unless otherwise agreed in writing, the prices stated in the PO include all federal, state, and local taxes, tariffs, import duties, commissions, and other charges.

14.1 Payment for acceptable Goods shall be made by Buyer or Buyer's Purchasing Agent, in accordance with the terms hereof, including a receipt by Buyer of the executed original copy of this PO, and receipt of Seller's invoice. At Buyer's sole option, payment may be by joint check to Buyer's Purchasing Agent and Seller. Seller agrees that Buyer will have an enforceable security interest or purchase money security interest in any equipment or materials for which Buyer or its Purchasing Agent has paid the Seller, and may perfect and enforce such security interest with no further notice to Seller. Seller agrees that this PO constitutes an enforceable security agreement with respect to such equipment or materials pursuant to Article 9 of the Uniform Commercial Code.

14.2 If and when requested by Buyer or its Purchasing Agent, Seller shall promptly provide a bill of sale, in a form provided or approved by the Owner, establishing the Owner's title in such equipment or materials, affidavits that all of Seller's supplier(s) have been paid and releases of all liens and other claims for payment either duly executed by Seller or Seller's supplier(s), and in a form suitable to Buyer. Such releases or waivers of lien rights and claims for payment may be conditional upon receipt of the payment for which submitted. Prior to final payment, Seller shall provide to Buyer copies of all warranties, applicable manuals and all other close-out documents required for the Goods under this Purchase Order.

15. INSURANCE: In the event that Seller or its employees or agents are required to come onto a Worksite or project of Buyer in connection with the sale of the Goods or the rendering of incidental services under this PO, including delivery of materials, Seller shall, prior to entrance on the Worksite or delivery of any Goods, purchase and maintain for a period of no less than twelve (12) months following the last delivery under this PO, insurance that will protect it from the claims arising out of its operations under this PO, including Worker's Compensation Insurance, Commercial General Liability and Automobile Liability Insurance. Seller shall maintain such insurance with the minimum limits of liability written by a company satisfactory to the Buyer as set forth below:



15.1 WORKER'S COMPENSATION including Occupational Disease insurance meeting the statutory requirements of the State in which Work is to be performed and containing Employers' Liability insurance in an amount of at least \$500,000.

15.2 COMMERCIAL GENERAL LIABILITY insurance on an occurrence basis providing limits for Bodily Injury and Personal Injury including its own employees of \$2,000,000 each occurrence for Major Trades and \$1,000,000 each occurrence for all other trades and Property Damage of \$2,000,000 each occurrence for Major Trades and \$1,000,000 each occurrence for all other trades. The policy must include the parties listed as ADDITIONAL INSUREDS, on an ISO Additional Insured Endorsement (CG 2010 and CG 2037) covering ongoing and completed operations. Subcontractor's insurance will be Primary and Non-Contributory to any insurance carried by any of the ADDITIONAL INSUREDS. In addition, Subcontractor shall maintain an **umbrella** liability policy providing the same coverage and with the same ADDITIONAL INSUREDS as the basic policy in the amount of \$5,000,000 for Major Trades and \$1,000,000 for all other trades.

15.3 COMPREHENSIVE AUTOMOBILE LIABILITY on an occurrence basis covering all Owned, Non-Owned and Hired Vehicles providing limits of liability for Bodily Injury and Personal Injury, including its own employees, of \$1,000,000 each occurrence and Property Damage of \$1,000,000 each occurrence.

15.4 If the services under this PO include the provision of professional architectural or engineering design services, Seller shall provide a standard form of Errors and Omissions or Professional Liability insurance with coverage of \$1 Million per occurrence and \$2 Million general aggregate.

ADDITIONAL INSUREDS FOR CONTRACTOR'S INSURANCE CERTIFICATE:

Certificate Holder:

Belmar HH Owner LLC

Additional Insureds:

Belmar HH Owner, LLC

THA Design Architecture

Concord Hospitality Enterprises Company

Hyatt House Franchising

16. SAFETY: Buyer contracts with Seller as an independent contractor to provide all Goods and other services necessary or incidental to perform this PO, subject as an employer to all applicable unemployment compensation, occupational health and safety, or similar statutes. Seller shall comply with all current safety requirements of Buyer identified in this PO, as well as all federal, state and local laws, regulations, ordinances and building codes applicable to the PO or Goods.

17. INDEMNITY: To the fullest extent permitted by law, Seller shall defend, indemnify and hold harmless Buyer and its agents, consultants, employees and others as required by this PO, from and against any and all liabilities whatsoever for damages and/or injuries to persons or property which may be incurred by Buyer by virtue of defective materials or workmanship in the Goods or incidental services furnished, including all costs and reasonable attorney's fees incurred. In addition, Seller agrees to indemnify and hold harmless Buyer from any costs arising out of a breach of warranty or incurred in connection with the enforcement of warranty under Article 13.

17.1 In the event that Seller, its employees or agents are required to come onto a Worksite or Project of Buyer in connection with the performance of this PO, without limiting Seller's obligations under this Article 17 and to the fullest extent permitted by law, Seller shall defend, indemnify and hold harmless Buyer and its agents, consultants, employees and others as required by this PO, from all claims for bodily injury and property damage that may arise out of the presence on the Worksite of Seller or subcontractors or suppliers to Seller, in connection with the performance of this PO, but only to the extent caused by the negligent acts or omissions or willful misconduct of Seller or anyone employed directly or indirectly by Seller or by anyone for whose acts Seller may be liable.

17.2 To the fullest extent permitted by law, Seller shall defend, indemnify and hold harmless Buyer and its agents, consultants, employees and others as required by this PO, from and against any and all claims or damages it may



incur due to Seller's failure to provide timely performance in accordance with this PO. To the extent the Owner-Buyer agreement provides for a mutual waiver of consequential damages by Owner and Buyer, Buyer and Seller waive claims against each other for the consequential damages arising out of or relating to this Purchase Order.

18. PATENTS: Seller shall defend, indemnify and hold Buyer and its agents, consultants, employees and others as required by this PO harmless from all suits or claims for infringement of any patent rights or copyrights arising out of the use or sale of the Goods and shall pay and discharge any and all judgments or decrees that may be rendered in any such suit, action or proceedings. Seller's obligations under this Article 18 shall not apply to Goods specified by Buyer.

19. COMPLIANCE WITH LAWS: Seller shall comply with all federal, state and local laws, regulations, codes and ordinances (the Laws) applicable to Seller, Buyer, and/or the incidental services covered by this PO, including but not limited to any such Laws relating to health and safety of any person; the environment; hazardous substances; labor and employment immigration; disadvantaged business enterprises; and civil rights. Seller shall be liable to Buyer for all loss, cost and expense attributable to any act or omission by Seller resulting from the failure to comply with Laws, including but not limited to any fines, penalties or corrective measures.

20. ASSIGNMENT: No assignment of this PO or of any right, obligation or interest in proceeds or any delegation of duty under this PO shall be made by Seller without express written consent of Buyer's authorized agent and any attempted assignment or delegation without such prior, written consent shall be void.

21. WAIVER: Buyer's failure to insist on performance of any term, condition, or instruction, or to exercise any right or privilege provided in this PO, or its waiver of any breach, shall not thereafter waive any such term, condition, instruction, and/or any right or privilege.

22. GOVERNING LAW: All sections of the Uniform Commercial Code that expressly or implicitly protect WFM and are not inconsistent with any term hereunder are hereby incorporated by reference. This PO shall be governed by the law in effect at the location of the Project without regard to its conflicts of laws principles.

23. DISPUTES: If a dispute arises out of or relates to this PO, the parties shall endeavor to settle the dispute through direct discussion. Disputes between Buyer and Seller not resolved by direct discussion shall be submitted to mediation pursuant to the Construction Industry Mediation Rules of the American Arbitration Association. The parties shall select the mediator within fifteen (15) days of the request for mediation. Engaging in mediation is a condition precedent to any form of binding dispute resolution. If neither direct discussions nor mediation successfully resolve this dispute, the parties agree that disputes shall be resolved via Arbitration pursuant to the Construction Industry Rules of the American unless the parties mutually agree otherwise. A written demand for arbitration shall be filed with the American Arbitration Association and the other party to the PO within a reasonable time after the dispute or claim has arisen, but in no event after the applicable statute of limitations for a legal or equitable proceeding has run. The arbitration award shall be final. This agreement to arbitrate shall be governed by the Federal Arbitration Act and judgment upon the award may be confirmed in any court having jurisdiction.

23.1 COST OF DISPUTE RESOLUTION: The cost of any mediation proceeding shall be shared equally by the parties participating. The prevailing party in any dispute that goes beyond mediation arising out of or relating to this PO or its breach shall be entitled to recover from the other party reasonable attorneys' fees, costs and expenses incurred by the prevailing party in connection with such dispute.

23.2 JOINDER: Notwithstanding the provisions in Section 23.1 above, in the event of a dispute between Buyer and any other person or entity involving the Goods, or a right, duty or obligation of Seller under this PO, Buyer may, if it elects, send Seller written notice of such dispute and Seller, if requested by Buyer, hereby consents to participate in any such mediation, arbitration or litigation in court as a party, whether by joinder, consolidation or otherwise.



24. JOINT DRAFTING: The parties expressly agree that this PO was jointly drafted and that they both had opportunity to negotiate terms and to obtain assistance of counsel in reviewing terms prior to execution. This PO shall be construed neither against nor in favor of either party, but shall be construed in a neutral manner.

25. CONFIDENTIALITY; USE OF NAME: Seller and its affiliates agree not to use the name, logos or trademarks of Buyer, its affiliates or the Project in any marketing, publicity, promotions, or other materials or in connection with the development of any proposed transaction or other business activities without Buyer's prior written consent. Seller may not express or imply any endorsement of its work or services, or the work or services of its affiliates, by Buyer.

Seller may, during its engagement, have access to, and acquire knowledge of or from, material, data, strategies, systems, or other information relating to the work, the Project or Buyer or its affiliates, that may not be accessible or known to the general public ("Owner's Materials"). Any Owner's Information received by Seller or its affiliates must be kept confidential and may not be used, published, or divulged by Seller or its affiliates to any other person in any manner without Buyer's written consent, which may be withheld in Buyer's sole and absolute discretion.

Seller may not undertake or allow any photography on or about the Project site without prior written consent of Buyer, which consent Buyer may withhold in its sole and absolute discretion. The provisions of this paragraph will survive the expiration or termination of this Agreement.

Date: Thursday, September 11, 2025
 Read Window Products, LLC
 5900 Weisbrook Lane
 Knoxville, TN 37909

Quote #: **25-594**

Project: **Hyatt House Denver Belmar
 Lakewood, CO**

Customer: **Concord Hospitality Enterprises**
 Requested by: **Sarah Forgacs**
Sarah.Forgacs@concordhotels.com



Prepared by: **Weston Moore**
 865-288-6242
wmoore@readwindow.com

End User Zip Code: _____

Qty	Area	Spec #	Treatment Dimensions		Product	Style #	Fabric	Yardage	Price	Price
			Width (inches)	Height (inches)						
113	GR	HHG-90-1	72	72	Custom Dual Roller Shade, Side Channels, Manual Bead Chain Clutch Control	Front Fabric: Jumble White/White 1% Back Fabric: Bergen B/O Storm Hardware: White			\$379.00	\$42,827.00
50	GR	HHG-90-1	36	72	Custom Dual Roller Shade, Side Channels, Manual Bead Chain Clutch Control	Front Fabric: Jumble White/White 1% Back Fabric: Bergen B/O Storm Hardware: White			\$281.50	\$14,075.00
15	GR	HHG-90-1	66	50	Custom Dual Roller Shade, Side Channels, Manual Bead Chain Clutch Control	Front Fabric: Jumble White/White 1% Back Fabric: Bergen B/O Storm Hardware: White			\$309.00	\$4,635.00
12	Suite	HHG-90-1	66	50	Custom Dual Roller Shade, Side Channels, Manual Bead Chain Clutch Control	Front Fabric: Jumble White/White 1% Back Fabric: Bergen B/O Storm Hardware: White			\$309.00	\$3,708.00
19	Suite	HHG-90-1	72	72	Custom Dual Roller Shade, Side Channels, Manual Bead Chain Clutch Control	Front Fabric: Jumble White/White 1% Back Fabric: Bergen B/O Storm Hardware: White			\$379.00	\$7,201.00
3	Suite	HHG-90-1	80	72	Custom Dual Roller Shade, Side Channels, Manual Bead Chain Clutch Control	Front Fabric: Jumble White/White 1% Back Fabric: Bergen B/O Storm Hardware: White			\$412.00	\$1,236.00
14	ADA	HHG-90-2	72	72	Custom Dual Roller Shade, Side Channels, 120v Powered Motorized Operation	Front Fabric: Jumble White/White 1% Back Fabric: Bergen B/O Storm Hardware: White			\$858.00	\$12,012.00
6	ADA	HHG-90-2	66	50	Custom Dual Roller Shade, Side Channels, 120v Powered Motorized Operation	Front Fabric: Jumble White/White 1% Back Fabric: Bergen B/O Storm Hardware: White			\$790.00	\$4,740.00
20	ADA	HHG-90-2			Multi Channel Battery Powered Wireless Wall Switch Controller	White			\$80.00	\$1,600.00
6	Lobby / Billiard Area	HHP-90-2	42	126	Custom Single Roller Shade, Manual Bead Chain Clutch Control	Fabric: Halden 3% / TBD Hardware: White			\$180.00	\$1,080.00
7	Lobby / The Commons	HHP-90-2	35	126	Custom Single Roller Shade, Manual Bead Chain Clutch Control	Fabric: Halden 3% / TBD Hardware: White			\$164.00	\$1,148.00
4	Lobby / The Commons	HHP-90-2	44	126	Custom Single Roller Shade, Manual Bead Chain Clutch Control	Fabric: Halden 3% / TBD Hardware: White			\$184.00	\$736.00

Qty	Area	Spec #	Treatment Dimensions		Product	Style #	Fabric	Yardage	Price	Price
			Width (inches)	Height (inches)		Fabric/Color	Yardage	Total	Each	Total
4	Lobby / Dining	HHP-90-2	44	126	Custom Single Roller Shade, Manual Bead Chain Clutch Control	Fabric: Halden 3% / TBD Hardware: White			\$184.00	\$736.00
8	Work Out Room	HHP-90-3	42	126	Custom Single Roller Shade, Manual Bead Chain Clutch Control	Fabric: Halden 3% / TBD Hardware: White			\$170.00	\$1,360.00
14	Gathering Room	HHP-90-4	40	114	Custom Single Roller Shade, Side Channels, Manual Bead Chain Clutch Control	Fabric: Arizona 0% / TBD Hardware: Anodized			\$278.00	\$3,892.00
5	Corridor	HHP-91-1	70	72	Custom Single Roller Shade, Manual Bead Chain Clutch Control	Fabric: Halden 3% / TBD Hardware: White			\$184.00	\$920.00
3					Measure Fee / Per Day				\$750.00	\$2,250.00
1					Installation Fee				\$28,500.00	\$28,500.00
1					Measure Travel Charge / Per Trip (Mileage, Time, & Per Diem)				\$1,500.00	\$1,500.00
3					Installation Travel Charge / Per Trip (Mileage, Time, & Per Diem)				\$2,000.00	\$6,000.00

Please note that all COM yardages above include a 5% waste factor.

\$140,156.00

PLEASE NOTE THAT DUE TO THE VOLATILITY IN TARIFF RATES. OUR QUOTES DO NOT INCLUDE POTENTIAL ADDITIONAL CHARGES RELATED TO TARIFFS. WE ADVISE ALL OUR CUSTOMERS TO CONFIRM THE QUOTE WITH OUR SALES TEAM PRIOR TO FINALIZING ANY ORDERS. THIS ENSURES YOU RECEIVE THE MOST ACCURATE QUOTE AND UPDATE INFORMATION ON PRICING.

ADDITIONAL EXPENSES NOT INCLUDED IN QUOTE ABOVE:

* FREIGHT IS **FOB SHIPPING POINT** AND WILL BE BILLED PRE-PAY & ADD UPON SHIPMENT(S) IF 3RD PARTY CARRIER INFORMATION IS NOT PROVIDED

* LODGING **ACCOMMODATIONS** FOR ONSITE SERVICES ARE NOT INCLUDED IN THE QUOTE ABOVE AND WILL BE BILLED AT APPLICABLE SEASONAL LOCAL RATES IF NOT PROVIDED BY THE SITE.

* **SALES TAX** WILL BE CHARGED ON APPLICABLE PRODUCTS/SERVICES ACCORDING TO LOCAL MUNICIPALITY OF SHIPPING DESTINATION UNLESS A CURRENT SALES TAX EXEMPTION/RESALE CERTIFICATE IS PROVIDED AT THE TIME OF ORDER. SHOULD RWP NOT COLLECT SALES TAX IN CITY/COUNTY/STATE OF THE DELIVERY SITE, NO TAX WILL BE CHARGED AND IT WILL BE THE CUSTOMER'S RESPONSIBILITY TO FILE USE TAX ACCORDINGLY.

***Please send order requests to Orders@readwindow.com

***Shades have been quoted using our in house product & fabrics to match HH Lansing as a spec

***Front fascia nor light blocking sill channels are included in above quote (not specified). If needed, surcharges will apply.

*** We were unable to find HHP-90-01 on the provided plans. If needed, please advise specs so they can be added to quote.

Qty	Area	Spec #	Treatment Dimensions		Product	Style #	Fabric/Color	Fabric	Yardage		Price	
			Width (inches)	Height (inches)					Yardage	Total	Each	Total

***Motorized shades will require power via 120v standard outlet within 5' of each motor location. Control is quoted via a battery powered wireless single channel wall switch. All electrical to be provided by OTHERS.

***Qty of trips to site have been hypothetically quoted based on specified scope of work for budgetary purposes. Qty & Cost of trips to be confirmed upon issue of project schedule.

***REV1: Revised quantities & sizes.

Terms & Conditions:

- 1 Freight is NOT included in above proposal and is to be Pre-pay & Add
- 2 Accommodations are not included & are prepay & add, unless provided by the site at no charge. If lodging is not provided by the site then lodging cost at applicable seasonal local rates per diem will be charged.
- 3 Above prices are subject to change unless confirmed by purchase order within 30 days of the posted date.
- 4 Payment Terms:
 100% Prepayment (Including Freight [when available] & Sales Tax) on Product Order Totals Under \$5,000 Must Be Received Prior to Start of Production
 50% Deposit on Product Order Totals Over \$5,000 & Services
 Balance is Due Upon Receipt of Completed Production and/or Services Rendered
 Invoicing May Be Progressively Billed & Final Shipping Charges Will Be Invoiced Upon Completion
 Additional Terms Subject to Credit Approval
- 5 Delivery is approximately six weeks from receipt of field measurements, proper purchase order documents, Receipt of required prepayments or deposits, and all fabrics related to the project.
- 6 Quotation is based on the total project being fabricated at one time. Production required in phases may be subject to additional charges.
- 7 Quotes are estimates and may vary from final cost. Accuracy is our goal, however errors do occur, therefore it is the customer's responsibility to verify accuracy of quote.
- 8 Final PO prices may change due to tariff uncertainty & final ship date.
- 9 Quotation is based on 1 trip to measure and 1 trip to install unless specifically stated otherwise. Additional trips, requests and deviations from the quotation is subject to change order.
- 10 Trip Charges for gas, flights, etc. are based on pricing as of the date of this quote and are subject to adjustment based on pricing at the time services are rendered.
- 11 All product will remain the sole property of Read Window Products, LLC until final payment is received. Liability is limited to total charge for product in question.
- 12 Yardages quoted are Customer's Own Material unless otherwise noted.
- 13 Installation services are non-union; union installation is subject to local union rates and regulations.
- 14 Installation into concrete, steel, or other difficult substrate may require additional charges.
- 15 Installation is to occur during normal business hours Monday - Friday. Anything outside of this basis is subject to additional charges and availability.
- 16 Read Window Products is responsible for discarding trash and debris related to the installation of the window treatments.
- 17 Lining provided by Read Window Products -- 3 Pass FR unless otherwise noted.
- 18 During installation Read Window Products will be allowed access to elevators, dumpsters and on-site equipment. Denial of access is subject to additional charges.
- 19 Occupied units and related hindrances of access to units may be subject to additional charges.
- 20 Removal of any existing window treatments is not included in the above proposal.
- 21 Steaming of draperies is not included in the above proposal.
- 22 COM Yardages quoted include 5% waste. All unconsumed remnants will be recycled after 45 days from substantial completion unless specifically instructed with other arrangements.
- 23 Customer is responsible for sales & use tax. In the event of tax exempt status, a resale certificate and W-9 must be included with Purchase Order.



Project Name: **Hyatt House V3 I2.0 GR**
Project #: **G Vol 3 Iss 2.0**
Issue Date: **06/01/25**

Item Number: **HHG-90-1-WT**
Item Description: **Dual Roller Shade Standard**
Area Name: **Guestroom**

Ceiling Height: VIF
Opening Size: Per plan - VIF
Mounting Method: Wall mounted
Pocket Dimensions: 6"H x 6"D, VIF
Hardware: Track by manufacturer

Shade Style: Manual Dual Roller Shade
Shade Dimensions: Verify in field
VENDOR: QUILTCRAFT
VENDOR: SUNBORN

Fabric Details QUILTCRAFT
Blackout: QC, SW 7200R, Sail, NF-SD
Sheer: QC, Longitude, Cloud, NF-NSS (stripes to run vertical)

SUNBORN
Blackout: Silient Night, Silver Lining
Sheer: Bella Lines, Angel Wings

- Notes:
1. Contract Dual Bracket, Roll-Ease SL20: Spring loaded idle end with locking clasps in clutch end; Chain diverter
 2. Blackout Side Channels: 2.5"W; Option for the channel to be powder coated matte black or powder coated anodized aluminum.
 3. Manual Pull Chains with Tie Downs; "Jumping" in the operation of the chain is not acceptable; Option for the chains to be powder coated matte black or powder coated anodized aluminum to match blackout side channel; Tie downs to coordinate.
 4. Blackout: Fabric wrapped, heat sealed hem bar; Extended T-hem bar; Standard roll, back
 5. Sheer: Fabric wrapped, heat sealed hem bar; Standard roll, back
 6. Sheer to be located on track 1 (front), blackout to be located on track 2 (back)
 7. Minimum Mounting Depth 5.5"D
 8. No Valance - to be contractor supplied
 9. Blocking by others

Required Item(s) for Designer Approval Prior to Fabrication:

Seaming Diagram Strike-Off Finish Sample Cutting Shop Dwgs Prototype Flame Certificate

Instructions:

- All specifications are intended to be used in conjunction with the Hyatt FF&E Preambles, the Global Technical Standards, and the Hyatt BEGs.

HHG-90-1-WT



Project Name: **Hyatt House V3 I2.0 GR**
Project #: **G Vol 3 Iss 2.0**
Issue Date: **06/01/25**

Item Number: **HHG-90-1-WT**
Item Description: **Dual Roller Shade Standard**
Area Name: **Guestroom**

Instructions:

- Refer to manufacturer's shop drawings. Shop drawings and all finish and material samples must be submitted if not using a current Hyatt approved vendor.
- All fabrication, materials, and finished goods must meet or exceed applicable federal, state, & local code requirements including fire & life safety & must be contract quality & suitable for commercial use. Residential grade products are not acceptable.

Project Name: **Hyatt House V3 I2.0 GR**
Project #: **G Vol 3 Iss 2.0**
Issue Date: **06/01/25**

Item Number: **HHG-90-1-WT**
Item Description: **Dual Roller Shade Standard**
Area Name: **Guestroom**



ROLLER SHADE - BLACKOUT



ROLLER SHADE - SHEER

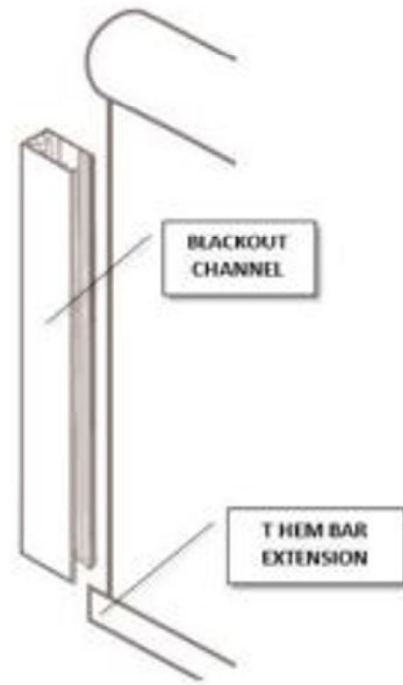

IMAGE FOR CONCEPT AND REFERENCE ONLY



Project Name: **Hyatt House V3 I2.0 GR**
Project #: **G Vol 3 Iss 2.0**
Issue Date: **06/01/25**

Item Number: **HHG-90-2-WT**
Item Description: **Dual Roller Shade Accessible**
Area Name: **Guestroom**

Ceiling Height: VIF
Opening Size: Per plan - VIF
Mounting Method: Wall mounted
Pocket Dimensions: 6"H x 6"D, VIF
Hardware: Track by manufacturer

Shade Style: Motorized Dual Roller Shade
Shade Dimensions: Verify in field
VENDOR: QUILTCRAFT
VENDOR: SUNBORN

Fabric Details QUILTCRAFT
Blackout: QC, SW 7200R, Sail, NF-SD
Sheer: QC, Longitude, Cloud, NF-NSS (stripes to run vertical)

SUNBORN
Blackout: Silent Night, Silver Lining
Sheer: Bella Lines, Angel Wings

- Notes:
1. Hardwired line voltage single-pole switch directly connected to tubular motors with full up and full down control
 2. All switched must be UL listed and meet local and national codes for indoor usage
 3. Blackout Side Channels: 2.5"W; Option for the channel to be powder coated matte black or powder coated anodized aluminum.
 4. Blackout: Fabric wrapped, heat sealed hem bar; Extended T-hem bar; Standard roll, back
 5. Sheer: Fabric wrapped, heat sealed hem bar; Standard roll, back
 6. Sheer to be located on track 1 (front), blackout to be located on track 2 (back)
 7. Minimum Mounting Depth 5.5"D
 8. No Valance - to be contractor supplied
 9. Blocking by others

Required Item(s) for Designer Approval Prior to Fabrication:

Seaming Diagram Strike-Off Finish Sample Cutting Shop Dwgs Prototype Flame Certificate

Instructions:

- All specifications are intended to be used in conjunction with the Hyatt FF&E Preambles, the Global Technical Standards, and the Hyatt BEGs.
- Refer to manufacturer's shop drawings. Shop drawings and all finish and material samples must be submitted if not using a current Hyatt approved vendor.

HHG-90-2-WT



Project Name: **Hyatt House V3 I2.0 GR**
Project #: **G Vol 3 Iss 2.0**
Issue Date: **06/01/25**

Item Number: **HHG-90-2-WT**
Item Description: **Dual Roller Shade Accessible**
Area Name: **Guestroom**

Instructions:

- All fabrication, materials, and finished goods must meet or exceed applicable federal, state, & local code requirements including fire & life safety & must be contract quality & suitable for commercial use. Residential grade products are not acceptable.

Project Name: **Hyatt House V3 I2.0 GR**
Project #: **G Vol 3 Iss 2.0**
Issue Date: **06/01/25**

Item Number: **HHG-90-2-WT**
Item Description: **Dual Roller Shade Accessible**
Area Name: **Guestroom**



ROLLER SHADE - BLACKOUT



ROLLER SHADE - SHEER

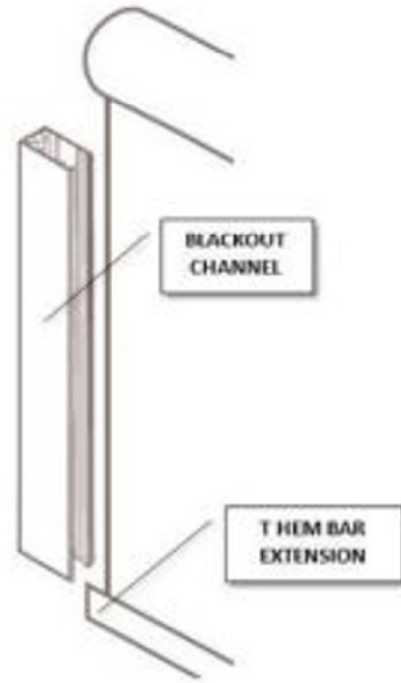

IMAGE FOR CONCEPT AND REFERENCE ONLY



Project Name: **Hyatt House V3 I2.0 PS**
Project #: **P Vol 3 Iss 2.0**
Issue Date: **06/01/25**

Item Number: **HHP-90-1-WT**
Item Description: **Drapery Sheer at Lobby Area**
Area Name: **Public Space**

Description: Fixed sheer drapery panels
Ceiling Height: V.I.F.
Opening Size: V.I.F.
Mounting Method: Ceiling mounted in pocket
Pocket Dimensions: V.I.F.
Hardware: Track by manufacturer
Top Treatment Style: Drapery pocket
Panels Style: Ripplefold
Panels Fixed or Operative: Fixed
Panels Fullness: 100%
Panels Finished Length: 0.5" AFF
Sheers Style: Sheer drapery

VENDOR: SUNBORN SHADING SOLUTIONS
VENDOR: QUILTCRAFT

COM/COL: HHP-90-1.1-WTF

Notes:

1. Installer to field measure prior to fabrication
2. Sheers to be installed inside drapery pocket. If different configuration is needed, adjustments to the window treatments and mounting hardware will need to be made accordingly
3. Fabric to be installed railroaded with pattern running vertically
4. French surge seams to be used
5. Flexible .25"W x .5"L chain weights with .5" fabric spacing in linear strip to be sewn in the bottom of hem to prevent billowing
6. Bottom of sheer is to hang .5" AFF or sill

Required Item(s) for Designer Approval Prior to Fabrication:

Seaming Diagram Strike-Off Finish Sample Cutting Shop Dwgs Prototype Flame Certificate

Instructions:

- All specifications are intended to be used in conjunction with the Hyatt FF&E Preambles, the Global Technical Standards, and the Hyatt BEGs.
- Refer to manufacturer's shop drawings. Shop drawings and all finish and material samples must be submitted if not using a current Hyatt approved vendor.

HHP-90-1-WT



Project Name: **Hyatt House V3 I2.0 PS**

Project #: **P Vol 3 Iss 2.0**

Issue Date: **06/01/25**

Item Number: **HHP-90-1-WT**

Item Description: **Drapery Sheer at Lobby Area**

Area Name: **Public Space**

Instructions:

- All fabrication, materials, and finished goods must meet or exceed applicable federal, state, & local code requirements including fire & life safety & must be contract quality & suitable for commercial use. Residential grade products are not acceptable.

HHP-90-1-WT



Project Name: **Hyatt House V3 I2.0 PS**
Project #: **P Vol 3 Iss 2.0**
Issue Date: **06/01/25**

Item Number: **HHP-90-1.1-WTF**
Item Description: **Fabric at Drapery Sheers at Lobby**
Area Name: **Public Space**

Width: 118"
Content: 100% Polyester
Railroad: Yes
Fire Rating: NFPA 701 Method #1
VENDOR: MOMENTUM TEXTILES - ITEM: NA-5C-G3HP109
Notes: Debut, Granite

Required Item(s) for Designer Approval Prior to Fabrication:

Seaming Diagram Strike-Off Finish Sample Cutting Shop Dwgs Prototype Flame Certificate

Instructions:

- All specifications are intended to be used in conjunction with the Hyatt FF&E Preambles, the Global Technical Standards, and the Hyatt BEGs.
- Refer to manufacturer's shop drawings. Shop drawings and all finish and material samples must be submitted if not using a current Hyatt approved vendor.
- All fabrication, materials, and finished goods must meet or exceed applicable federal, state, & local code requirements including fire & life safety & must be contract quality & suitable for commercial use. Residential grade products are not acceptable.

Project Name: **Hyatt House V3 I2.0 PS**
Project #: **P Vol 3 Iss 2.0**
Issue Date: **06/01/25**

Item Number: **HHP-90-1.1-WTF**
Item Description: **Fabric at Drapery Sheers at Lobby**
Area Name: **Public Space**

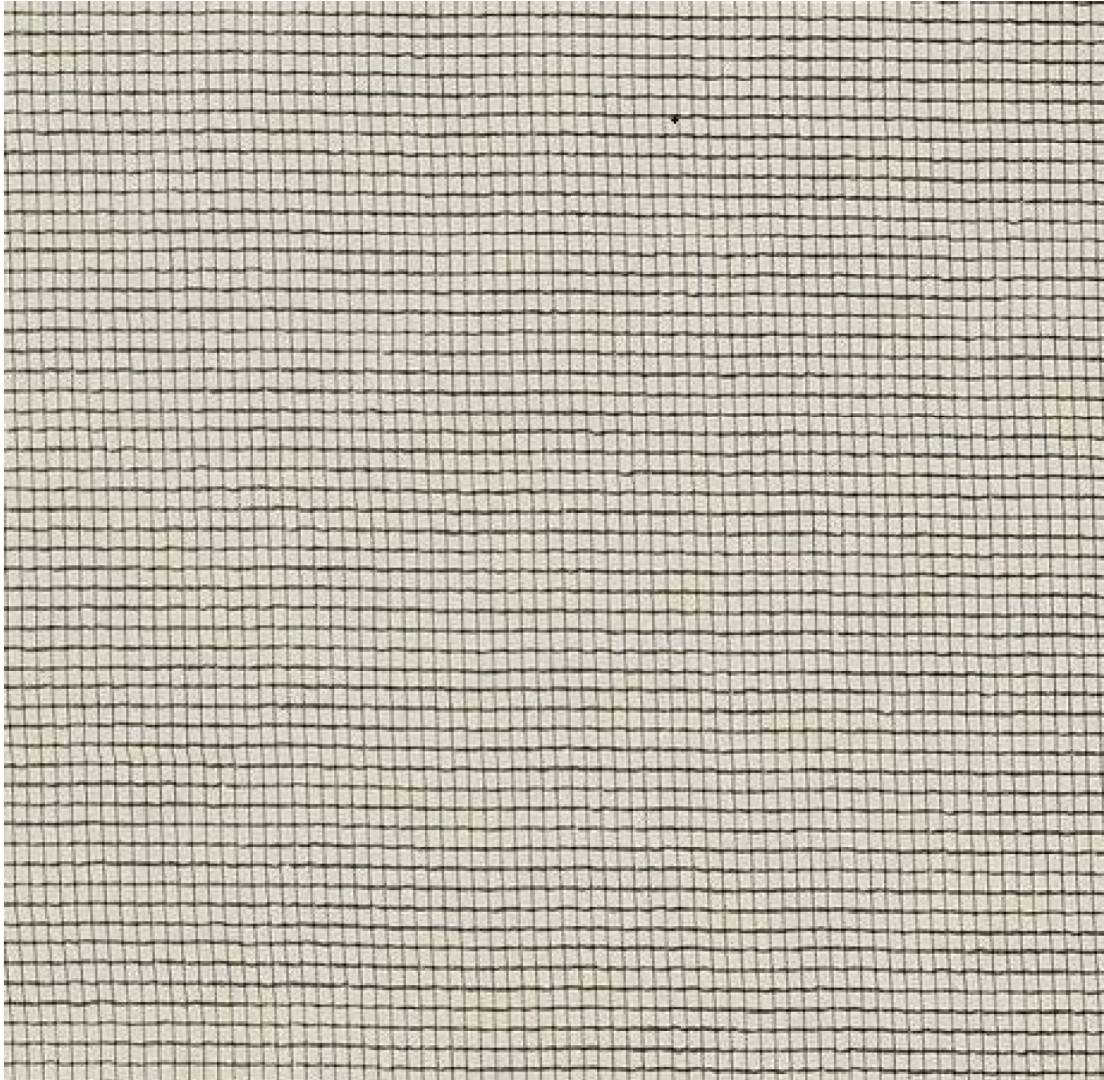

IMAGE FOR CONCEPT AND REFERENCE ONLY



Project Name: **Hyatt House V3 I2.0 PS**
Project #: **P Vol 3 Iss 2.0**
Issue Date: **06/01/25**

Item Number: **HHP-90-2-WT**
Item Description: **Roller Shade at Lobby Area**
Area Name: **Public Space**

Ceiling Height: V.I.F.
Opening Size: V.I.F.
Mounting Method: Ceiling Mounted - Inside Drapery Pocket
Pocket Dimensions: V.I.F.

Shade Style: Roller Shades FR
Shade Dimensions: V.I.F.
VENDOR: SUNBORN SHADING SOLUTIONS
VENDOR: QUILTCRAFT
Fabric Details: Pattern: Lunara Solar FR
Color: DW White Linen
Contents: 28% Polyester, 72% PVC
Openness: 10%

Notes:

1. Installer must field measure ALL windows prior to ordering.
2. Operating Systems: Standard roll, manual operation by stainless steel ball chain, universal clutch for left or right hand chain operation. Chains must be on the same sides and be securely attached to the clear colored locking devices (i.e. tensions device clip/chain hold-down) for safe use.
3. If ownership wished to have these shades be motorized, specific electrical requirements will need to be provided.
4. Width of shades will be determined by the size of the window bay. Each window bay should have it's own shade. Shades that are too wide may start to curl inward.
5. Shades should be mounted on the ceiling inside the window return and extend down the sill.
6. "Stop beads" must be installed on the chain to allow for proper operation, which prevents the over rotation of the roller shades.

Required Item(s) for Designer Approval Prior to Fabrication:

Seaming Diagram Strike-Off Finish Sample Cutting Shop Dwgs Prototype Flame Certificate

Instructions:

- All specifications are intended to be used in conjunction with the Hyatt FF&E Preambles, the Global Technical Standards, and the Hyatt BEGs.
- Refer to manufacturer's shop drawings. Shop drawings and all finish and material samples must be submitted if not using a current Hyatt approved vendor.
- All fabrication, materials, and finished goods must meet or exceed applicable federal, state, & local code requirements including fire & life safety & must be contract quality & suitable for commercial use. Residential grade products are not acceptable.

HHP-90-2-WT

Project Name: **Hyatt House V3 I2.0 PS**
Project #: **P Vol 3 Iss 2.0**
Issue Date: **06/01/25**

Item Number: **HHP-90-2-WT**
Item Description: **Roller Shade at Lobby Area**
Area Name: **Public Space**

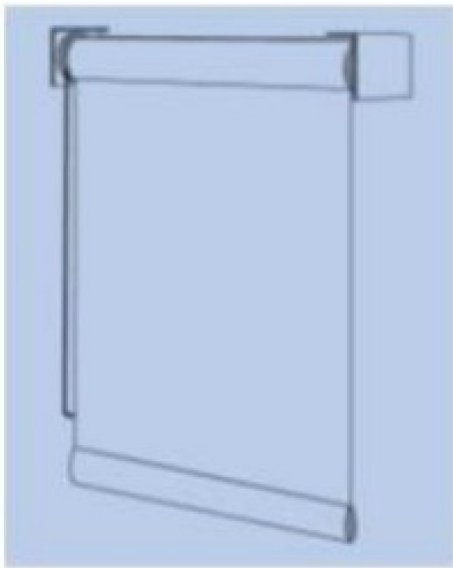

IMAGE FOR CONCEPT AND REFERENCE ONLY



Project Name: **Hyatt House V3 I2.0 PS**
Project #: **P Vol 3 Iss 2.0**
Issue Date: **06/01/25**

Item Number: **HHP-90-3-WT**
Item Description: **Roller Shade at Fitness**
Area Name: **Public Space**

Ceiling Height: V.I.F.
Opening Size: V.I.F.
Mounting Method: Ceiling Mounted
Pocket Dimensions: V.I.F.

Shade Style: Roller Shades FR
Shade Dimensions: V.I.F.
VENDOR: SUNBORN SHADING SOLUTIONS
VENDOR: QUILTCRAFT
Fabric Details: Pattern: Lunara Solar FR
Color: DW White Linen
Contents: 28% Polyester, 72% PVC
Openness: 10%

Notes:

1. Installer must field measure ALL windows prior to ordering.
2. Operating Systems: Standard roll, manual operation by stainless steel ball chain, universal clutch for left or right hand chain operation. Chains must be on the same sides and be securely attached to the clear colored locking devices (i.e. tensions device clip/chain hold-down) for safe use.
3. If ownership wished to have these shades be motorized, specific electrical requirements will need to be provided.
4. Width of shades will be determined by the size of the window bay. Each window bay should have it's own shade. Shades that are too wide may start to curl inward.
5. Shades should be mounted on the ceiling inside the window return and extend down the sill.
6. "Stop beads" must be installed on the chain to allow for proper operation, which prevents the over rotation of the roller shades.

Required Item(s) for Designer Approval Prior to Fabrication:

Seaming Diagram Strike-Off Finish Sample Cutting Shop Dwgs Prototype Flame Certificate

Instructions:

- All specifications are intended to be used in conjunction with the Hyatt FF&E Preambles, the Global Technical Standards, and the Hyatt BEGs.
- Refer to manufacturer's shop drawings. Shop drawings and all finish and material samples must be submitted if not using a current Hyatt approved vendor.
- All fabrication, materials, and finished goods must meet or exceed applicable federal, state, & local code requirements including fire & life safety & must be contract quality & suitable for commercial use. Residential grade products are not acceptable.

HHP-90-3-WT

Project Name: **Hyatt House V3 I2.0 PS**
Project #: **P Vol 3 Iss 2.0**
Issue Date: **06/01/25**

Item Number: **HHP-90-3-WT**
Item Description: **Roller Shade at Fitness**
Area Name: **Public Space**

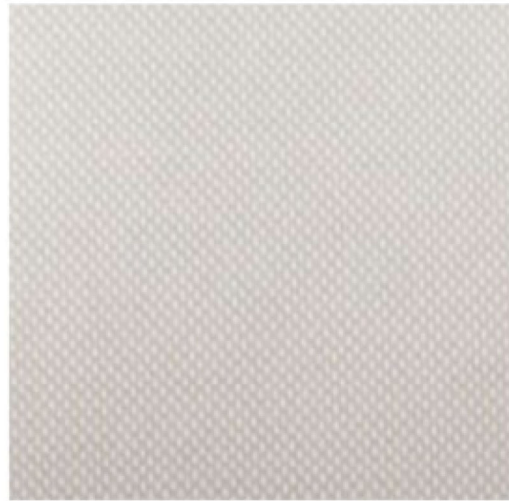
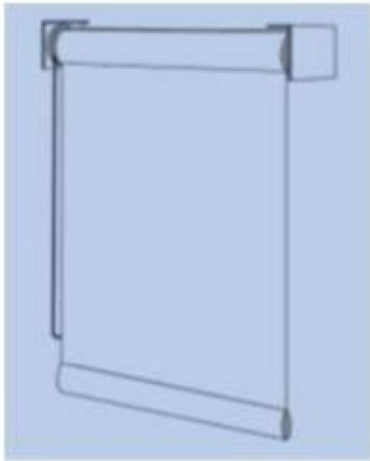

IMAGE FOR CONCEPT AND REFERENCE ONLY



Project Name: **Hyatt House V3 I2.0 PS**
Project #: **P Vol 3 Iss 2.0**
Issue Date: **06/01/25**

Item Number: **HHP-90-4-WT**
Item Description: **Roller shade at Gathering Room**
Area Name: **Public Space**

Ceiling Height: V.I.F.
Opening Size: V.I.F.
Mounting Method: Ceiling Mounted - Inside Drapery Pocket
Pocket Dimensions: V.I.F.

Shade Style: Roller Shades FR
Shade Dimensions: V.I.F.

VENDOR: SUNBORN SHADING SOLUTIONS
VENDOR: QUILTCRAFT
Fabric Details: Pattern: CNRD FR Blackout
Color: Silver Gray
Contents: 100% Polyester, w/Foam Backing
Openness: 0%

Notes:

1. Installer must field measure ALL windows prior to ordering.
2. Operating Systems: Standard roll, manual operation by stainless steel ball chain, universal clutch for left or right hand chain operation. Chains must be on the same sides and be securely attached to the clear colored locking devices (i.e. tensions device clip/chain hold-down) for safe use.
3. If ownership wished to have these shades be motorized, specific electrical requirements will need to be provided.
4. Width of shades will be determined by the size of the window bay. Each window bay should have it's own shade. Shades that are too wide may start to curl inward.
5. Shades should be mounted on the ceiling inside the window return and extend down the sill.
6. Side channels to be located on sides, mounted to wall and match window frame finish. This is to ensure there is no light leakage. Prototypical side channel finish is to be Anodized Aluminum.
7. "Stop beads" must be installed on the chain to allow for proper operation, which pr

Required Item(s) for Designer Approval Prior to Fabrication:

<input type="checkbox"/> Seaming Diagram	<input type="checkbox"/> Strike-Off	<input type="checkbox"/> Finish Sample	<input type="checkbox"/> Cutting	<input type="checkbox"/> Shop Dwgs	<input type="checkbox"/> Prototype	<input type="checkbox"/> Flame Certificate
--	-------------------------------------	--	----------------------------------	------------------------------------	------------------------------------	--

Instructions:

- All specifications are intended to be used in conjunction with the Hyatt FF&E Preambles, the Global Technical Standards, and the Hyatt BEGs.
- Refer to manufacturer's shop drawings. Shop drawings and all finish and material samples must be submitted if not using a current Hyatt approved vendor.

HHP-90-4-WT



Project Name: **Hyatt House V3 I2.0 PS**

Project #: **P Vol 3 Iss 2.0**

Issue Date: **06/01/25**

Item Number: **HHP-90-4-WT**

Item Description: **Roller shade at Gathering Room**

Area Name: **Public Space**

Instructions:

- All fabrication, materials, and finished goods must meet or exceed applicable federal, state, & local code requirements including fire & life safety & must be contract quality & suitable for commercial use. Residential grade products are not acceptable.

HHP-90-4-WT

Project Name: **Hyatt House V3 I2.0 PS**
Project #: **P Vol 3 Iss 2.0**
Issue Date: **06/01/25**

Item Number: **HHP-90-4-WT**
Item Description: **Roller shade at Gathering Room**
Area Name: **Public Space**

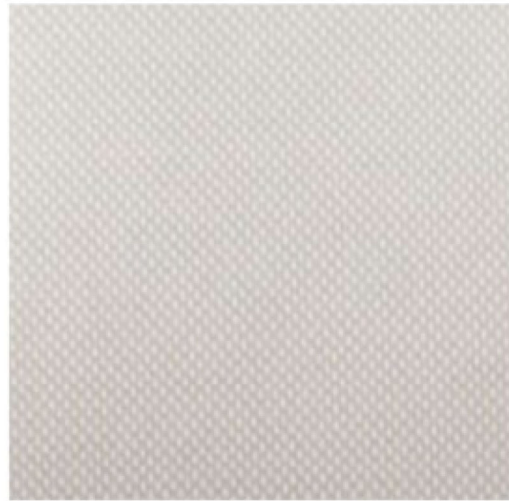
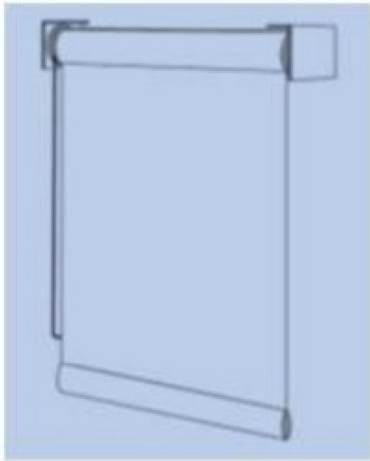

IMAGE FOR CONCEPT AND REFERENCE ONLY



Project Name: **Hyatt House V3 I2.0 PS**
Project #: **P Vol 3 Iss 2.0**
Issue Date: **06/01/25**

Item Number: **HHP-91-1-WT**
Item Description: **Roller Shade at Corridor**
Area Name: **Public Space**

Ceiling Height: V.I.F.
Opening Size: V.I.F.
Mounting Method: Ceiling Mounted - Inside Drapery Pocket
Pocket Dimensions: V.I.F.

Shade Style: Roller Shades FR
Shade Dimensions: V.I.F.
VENDOR: SUNBORN SHADING SOLUTIONS
VENDOR: QUILTCRAFT
Fabric Details: Pattern: Lunara Solar FR
Color: DW White Linen
Contents: 28% Polyester, 72% PVC
Openness: 10%

Notes:

1. Installer must field measure ALL windows prior to ordering.
2. Operating Systems: Standard roll, manual operation by stainless steel ball chain, universal clutch for left or right hand chain operation. Chains must be on the same sides and be securely attached to the clear colored locking devices (i.e. tensions device clip/chain hold-down) for safe use.
3. If ownership wished to have these shades be motorized, specific electrical requirements will need to be provided.
4. Width of shades will be determined by the size of the window bay. Each window bay should have it's own shade. Shades that are too wide may start to curl inward.
5. Shades should be mounted on the ceiling inside the window return and extend down the sill.
6. "Stop beads" must be installed on the chain to allow for proper operation, which prevents the over rotation of the roller shades.

Required Item(s) for Designer Approval Prior to Fabrication:

Seaming Diagram Strike-Off Finish Sample Cutting Shop Dwgs Prototype Flame Certificate

Instructions:

- All specifications are intended to be used in conjunction with the Hyatt FF&E Preambles, the Global Technical Standards, and the Hyatt BEGs.
- Refer to manufacturer's shop drawings. Shop drawings and all finish and material samples must be submitted if not using a current Hyatt approved vendor.
- All fabrication, materials, and finished goods must meet or exceed applicable federal, state, & local code requirements including fire & life safety & must be contract quality & suitable for commercial use. Residential grade products are not acceptable.

HHP-91-1-WT

Project Name: **Hyatt House V3 I2.0 PS**
Project #: **P Vol 3 Iss 2.0**
Issue Date: **06/01/25**

Item Number: **HHP-91-1-WT**
Item Description: **Roller Shade at Corridor**
Area Name: **Public Space**

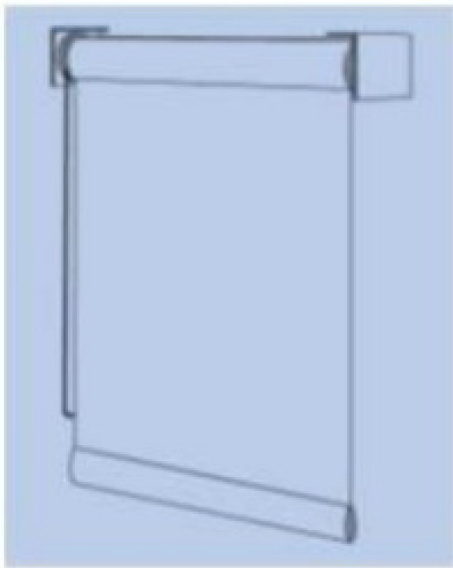

IMAGE FOR CONCEPT AND REFERENCE ONLY